

Single IC 48 V Power Management Battery Maintenance/Backup System

A common trend for electronic devices is increased portability; it is no longer universally acceptable for a device to turn off simply because somebody “pulled the plug.” In order to implement portable functionality, devices must include advanced power management systems that can control the path of power from available sources to appropriate system outputs, keep a backup element charged and ready, and ensure that a system has adequate power at all times. Elegant, single-IC power management solutions are readily available for many portable devices, such as smart phones or tablets, which operate at low voltages and low power levels. Power management solutions for high power and high voltage systems, such as those required for many industrial or medical devices, generally require cumbersome and complex specialized discrete component solutions. The LTC4020 simplifies power management in these environments by incorporating advanced power management functions into a high voltage and high power single-IC solution.

Jay Celani, Design Engineer, Power Management Products, Linear Technology Corp., USA

The LTC4020 features an advanced 4-switch buck/boost DC/DC power converter, support for optimized battery charging, and Linear Technology’s proprietary PowerPath™ system/battery power management functionality. The LTC4020 manages power distribution between the system input supply, the backup battery, and the converter output in response to load variations, battery charge requirements and input power limitations.

The single-inductor DC/DC buck/boost controller can accept input voltages up to 55 V and produce voltages that are lower, higher, or the same as the input voltage. The onboard battery charger can be configured to provide a constant-current/constant-voltage (CC/CV) charge profile optimized for lithium-based batteries, a 3-stage lead-acid battery charge profile, or a modified timer-terminated constant-current algorithm (CC), which is similar to the lithium profile but does not incorporate low voltage precondition and charge cycle restart functions.

Using CC mode charging to bend the rules for a 48 V lead-acid charger

When the LTC4020 is configured in the charge mode optimized for lead-acid batteries, the regulation voltage during absorption charging is 120 % of the typical battery system voltage, or 14.4V for a “12

V” lead-acid battery. Unfortunately, the built-in lead-acid charge algorithm cannot be used for a 48 V system battery, since the absorption charge voltage would exceed the operating maximum voltage for the LTC4020. This can be easily addressed by implementing a high current float charger using the constant-current (CC) charge algorithm.

The CC charge algorithm is enabled by leaving the LTC4020’s MODE pin unconnected. A feedback resistor divider programs the desired battery float charge voltage, corresponding to $V_{FB} = 2.5$ V. The CC charge algorithm enables the full programmed charge current until the float regulation voltage is achieved. While maintaining the float regulation voltage, a lead-acid float charger must be able to continuously source current into the battery, so the charge function cannot terminate. CC charge mode can accommodate this by setting $TIMER = 0$ V, which disables the timer function and thus disables charge termination, so the charge cycle will continue indefinitely.

48 V system power supply with lead-acid battery backup

Figure 1 shows an LTC4020 configured as a 48 V system supply with an integrated backup battery float charger. The central component of this supply is an average current-mode buck/boost DC/DC controller, employing four external NFETs

as switching elements, which provides 265 W of available output system power.

The converter operates from a 36 – 55 V input supply, with the converter limited to 8.3 A of average inductor current. The converter current limit is programmed by two 6 mΩ sense resistors (R_{SENSE1} and R_{SENSE2}) placed in series with SiS862DN switching FETs M1 and M2. The DC/DC converter supports at least 5 A at its output over the entire operating voltage range.

R_{SHDN1} and R_{SHDN2} form a divider at the SHDN pin, which sets the input shutdown voltage at $V_{IN} = 35$ V, disabling the DC/DC converter and battery charger functions when the input is below 35 V, so full load current is available whenever the supply is enabled. The SiS862DN switch FETs used here have a typical Q_G of about 10 nC each, so with the operating frequency set to 250 kHz by resistor R_r , the $Q_{G(TOTAL)} \cdot f_0$ at $V_{IN} = 55$ V falls within the LTC4020’s specified INTVCC pass element SOA guidelines.

The IC charges and maintains a 24-cell (48 V) lead-acid backup battery using a constant-current/constant-voltage charge profile as previously described. The maximum battery charge current is programmed by R_{CS} to 5 A, which is available until the full-charge float voltage of 53.75 V is achieved (Figure 2). The battery voltage is monitored by a resistor divider (R_{FB1} and R_{FB2}), which programs the

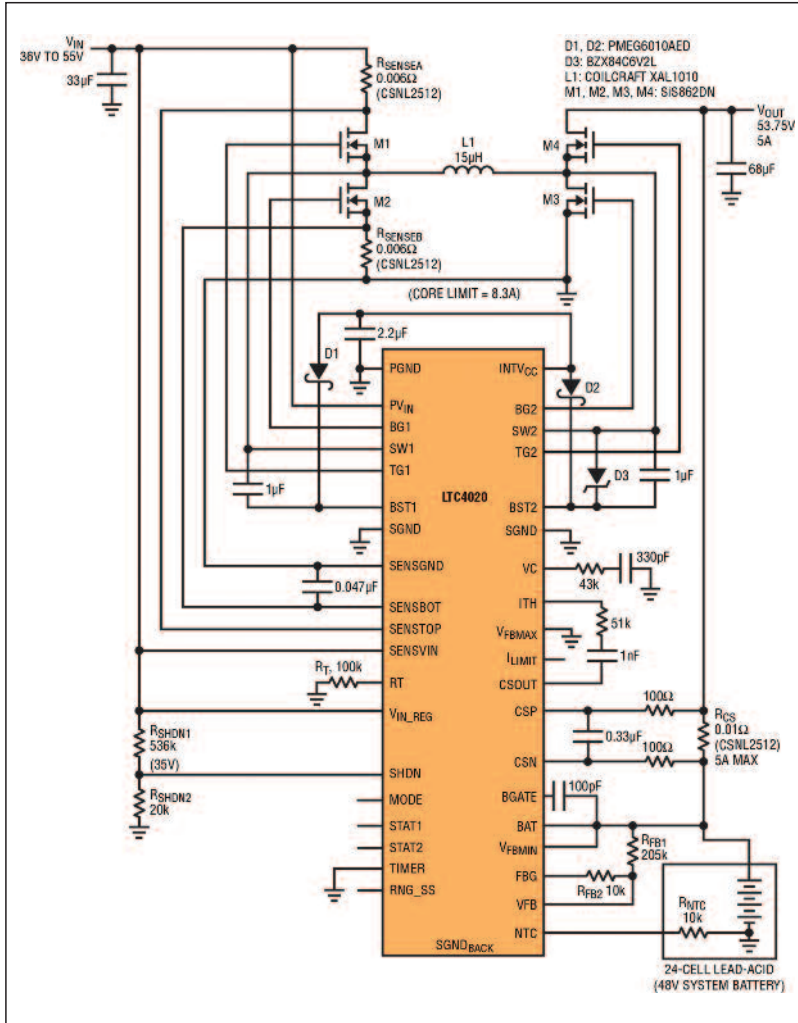

Figure 1: 36 V to 55 V to 24-cell lead-acid (48 V) float charger/system supply with 265 W converter output capability, 5 A battery charge current and 53.75 V system/float charge voltage output

direction, and load current will be sourced from the battery to supplement the converter output. Figure 3 shows the available converter output current (system load current + battery charge current) vs input voltage.

When the V_{IN} supply is disconnected, all LTC4020 functions cease and the battery supplies required power to the output. Reverse conduction from the battery through the converter is blocked by the switch FET M4, the battery voltage monitor resistor divider is disconnected via pin FBG, and total battery current into the IC is reduced to less than 10 μ A, maximizing battery life should a no-load storage condition be required.

Conclusion

The LTC4020 is a single-IC power management solution for any high power device that requires battery backup or battery-powered remote operation. The integrated buck/boost DC/DC controller can provide power to a voltage rail that is above, below or equivalent to the input voltage. The IC employs an intelligent PowerPath topology, merging the controller output to a full-featured multi-chemistry battery charger. The charger includes an internal onboard timer for charge cycle control and real-time charge cycle monitoring using binary-coded status pins. Three pin-selectable charging profiles provide versatility to accommodate most common battery types with optimized charging characteristics.

full-charge float voltage of 53.75 V (or 2.24 V/cell). This divider is referenced through the FBG pin, which is shorted to ground when the LTC4020 is operating, but becomes high impedance when the IC is disabled, reducing the parasitic load on the battery.

The LTC4020 preferentially provides

power to the system load and battery charging functions - the system load is always prioritized over charging power - so battery charge current is reduced when necessary during periods of heavy loads. Should the system load exceed the capabilities of the LTC4020 DC/DC converter, battery current will change

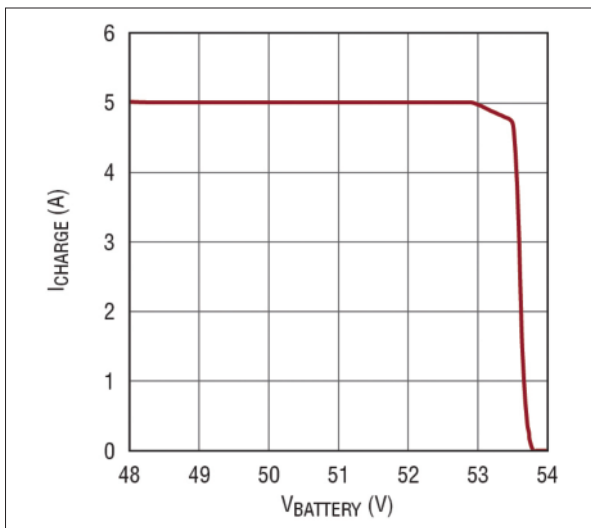

Figure 2: Maximum battery charge current for the circuit shown in Figure 1

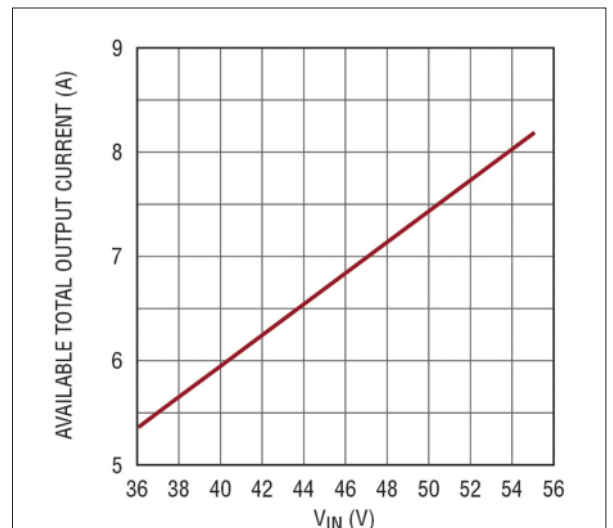

Figure 3: Available converter output current (system load current + battery charge current) vs input voltage